

A Green Internet

Information Logistics and Energy

Rod Tucker

**ARC Special Research Centre for
Ultra-Broadband Information Networks (CUBIN)**

**My Friends:
Jayant Baliga, Kerry Hinton, Rob Ayre**



Energy and the Internet

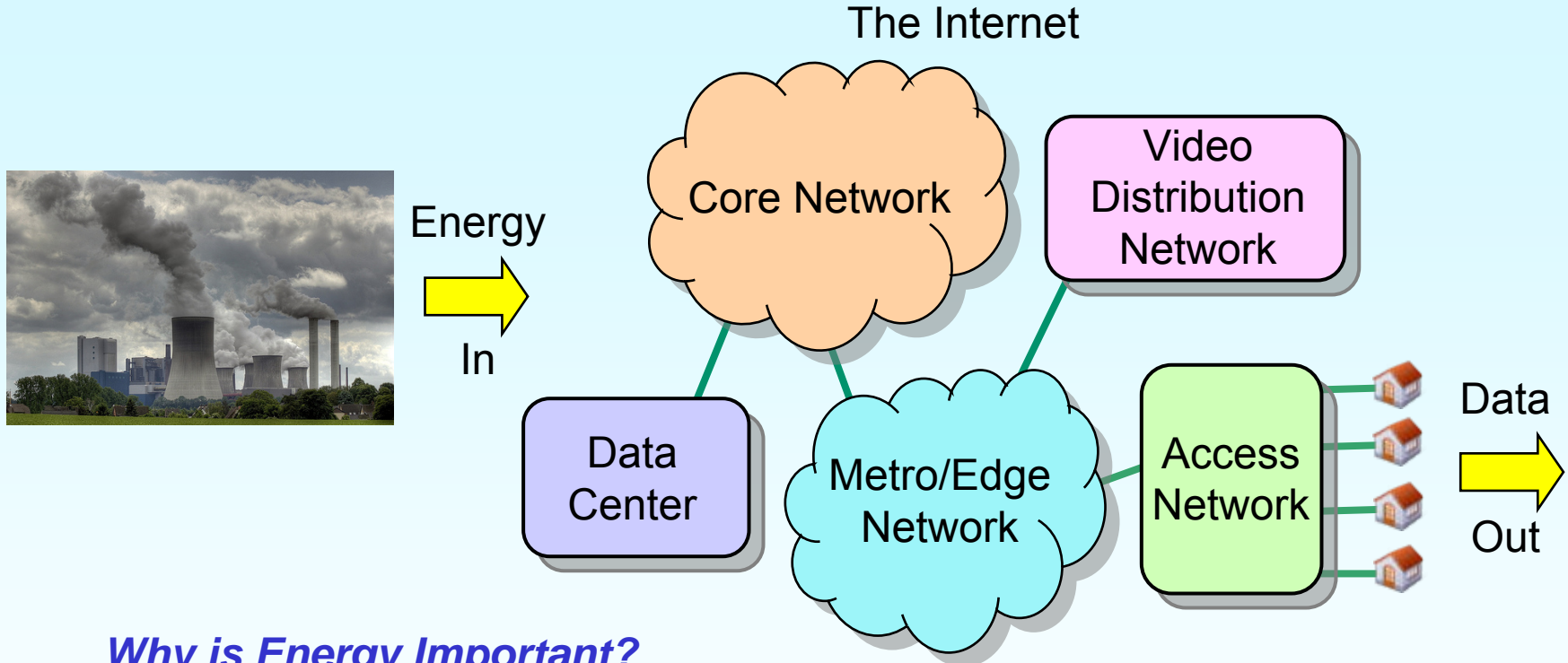

Why is Energy Important?

- OPEX
- Greenhouse Impact
- Energy-limited capacity bottlenecks (“hot spots”)
- Enabling energy efficiencies in other sectors

Putting Things into Context

Information and Communication Technologies (ICT)

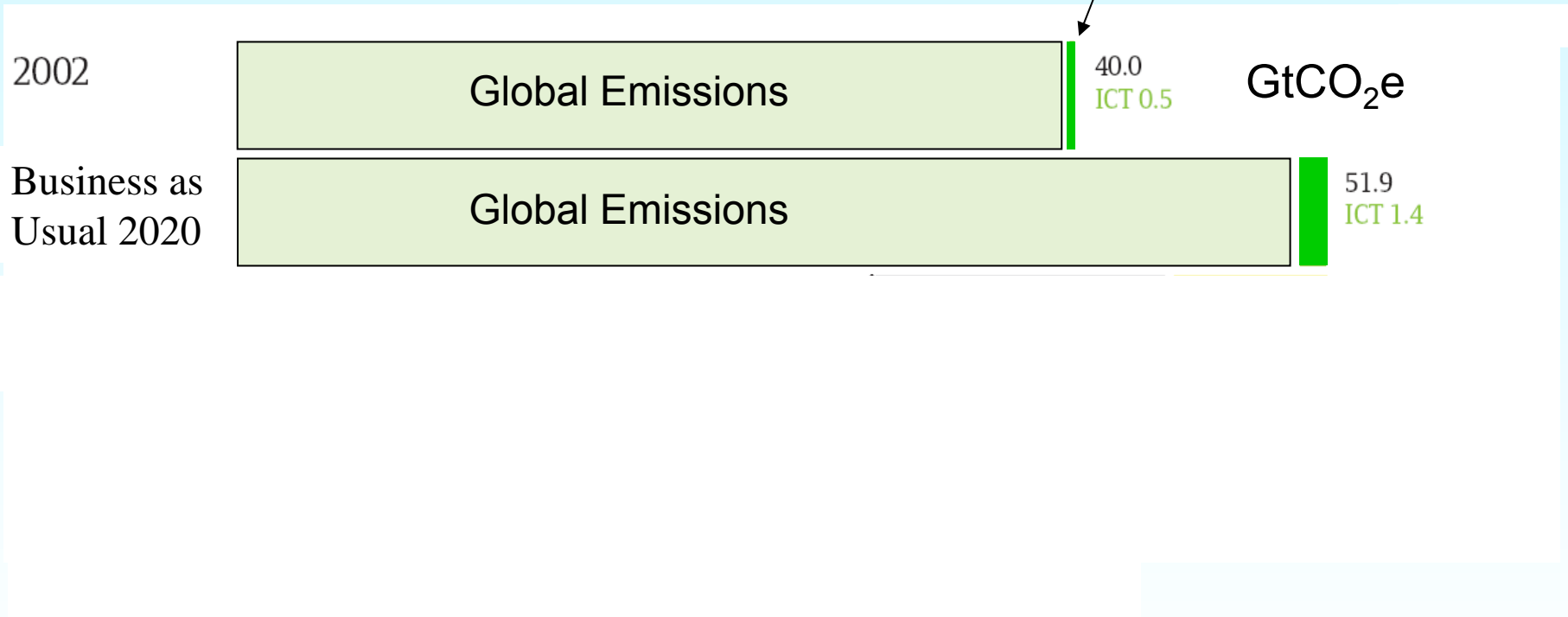

“SMART 2020: Enabling the low carbon economy in the information age,”
GeSI, 2008 www.gesi.org



Summary

- Estimating energy consumption of the Internet
- Where is the energy consumed
 - Core, metro, access network, data centres?
- Information Logistics
 - Cloud Computing
 - Travel Replacement
 - Airmail vs. Internet
- The Khazzoom-Brookes postulate

Caveat: “Making predictions is difficult – especially about the future.”

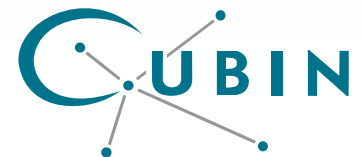

Network Energy Model

Tier 1 Network

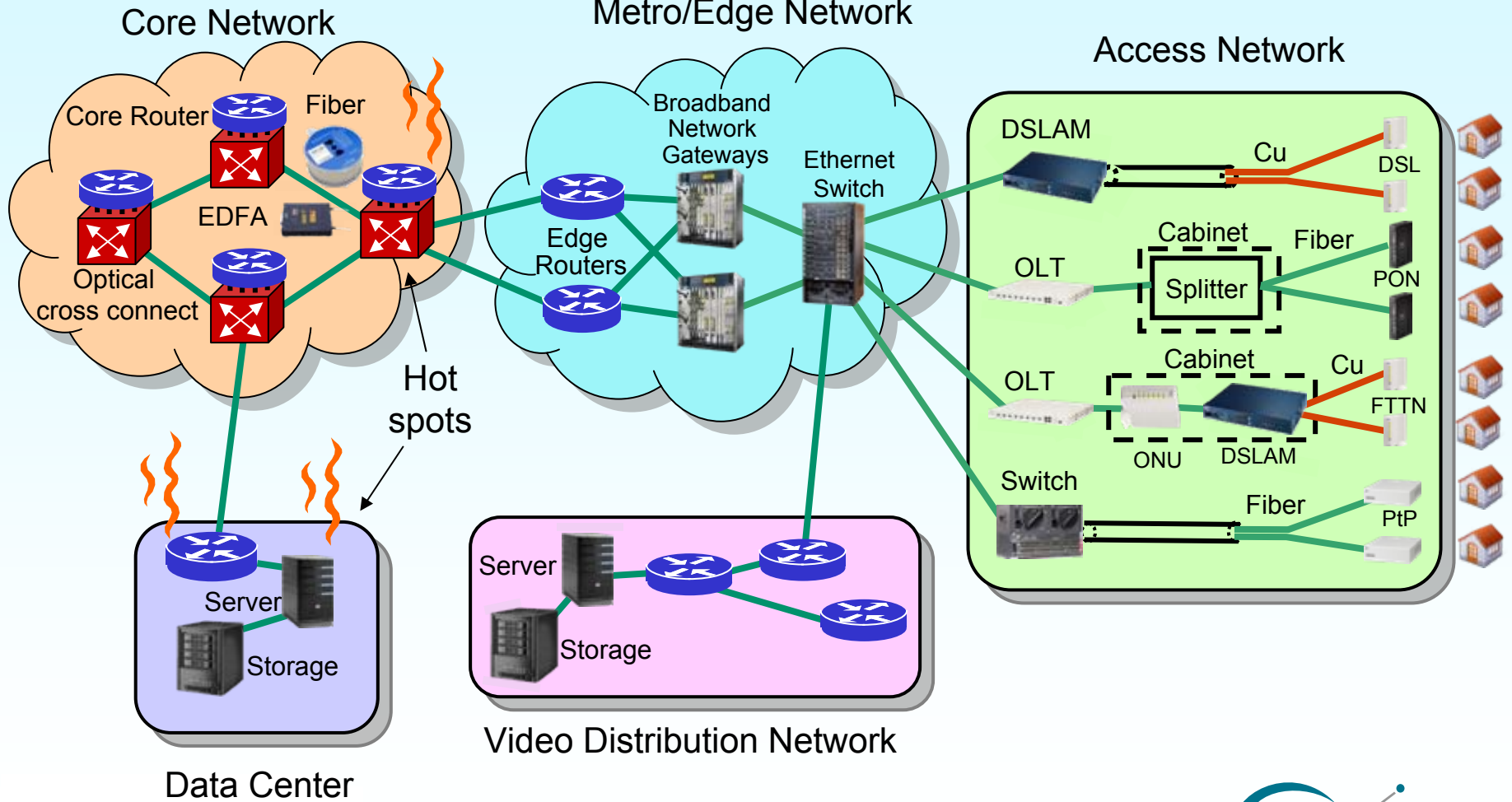

Oversubscription

Oversubscription

$$M = \frac{\text{Peak access rate sold to user}}{\text{Average access rate}}$$

~ 3 Mb/s in 2009

$M = 25$

~ 0.12 Mb/s in 2009



Power Consumption of IP Network

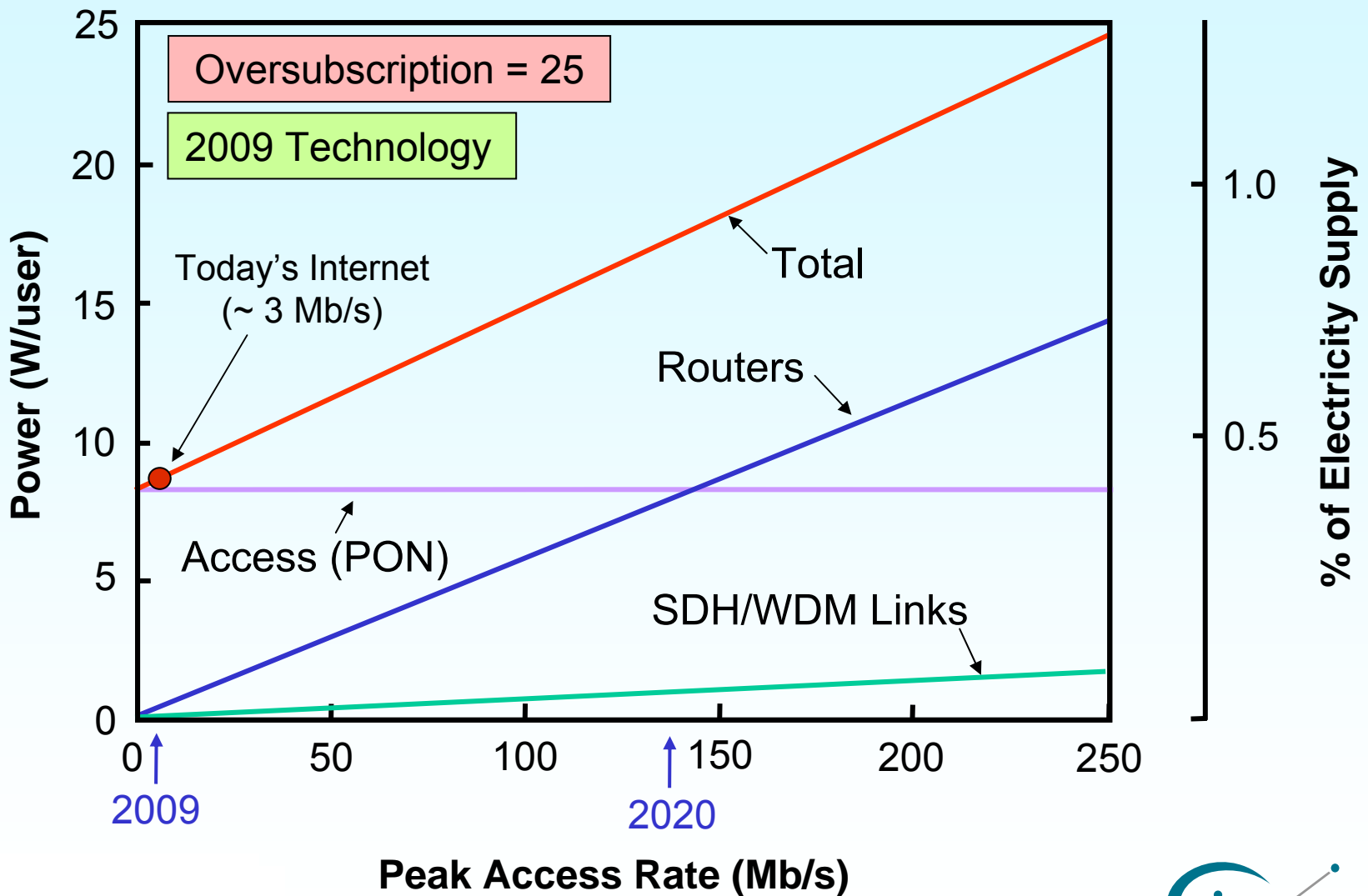

Traffic Growth = 40% p.a



Power Consumption in Access Networks

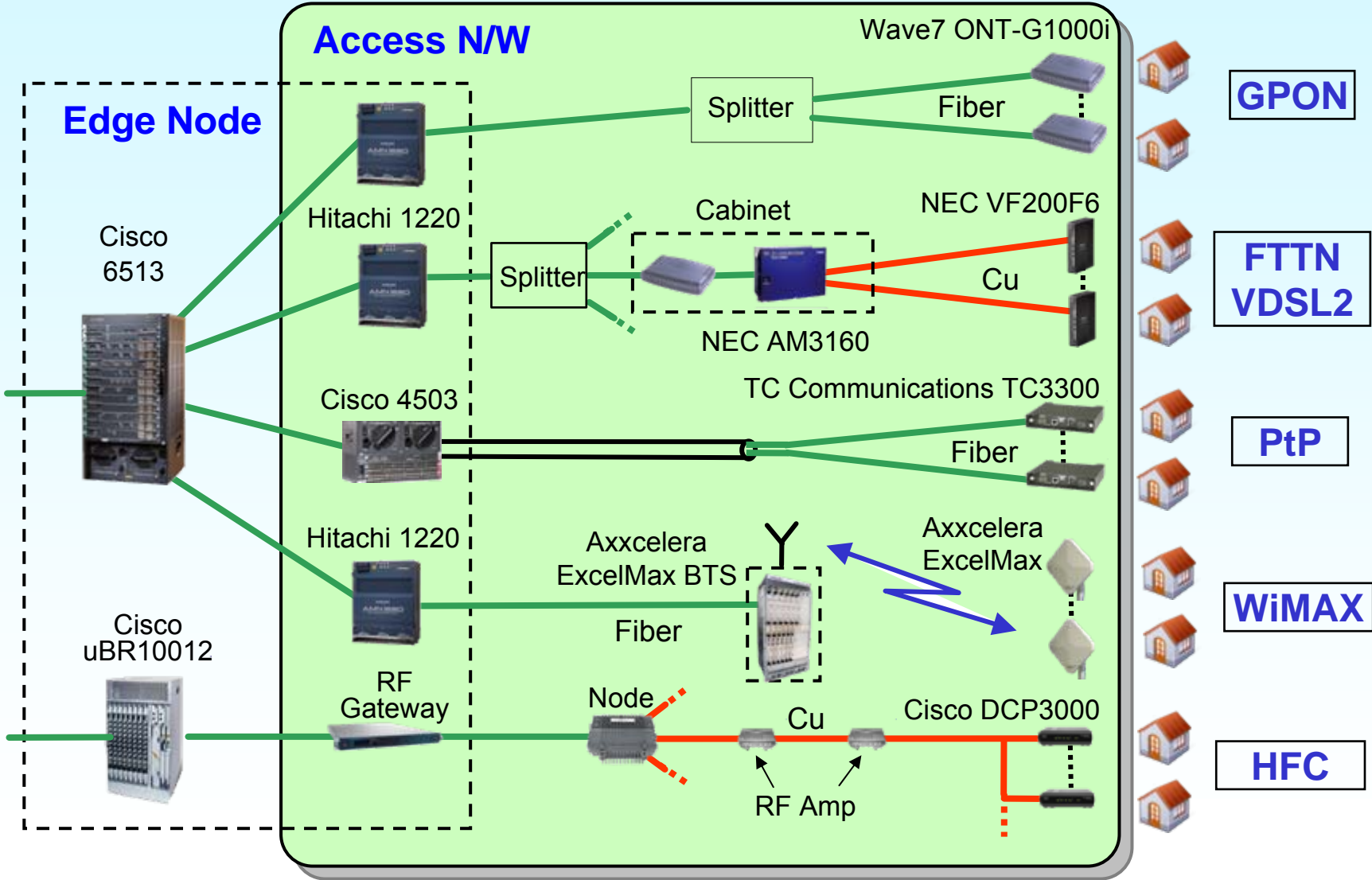

Power Consumption in Access Networks

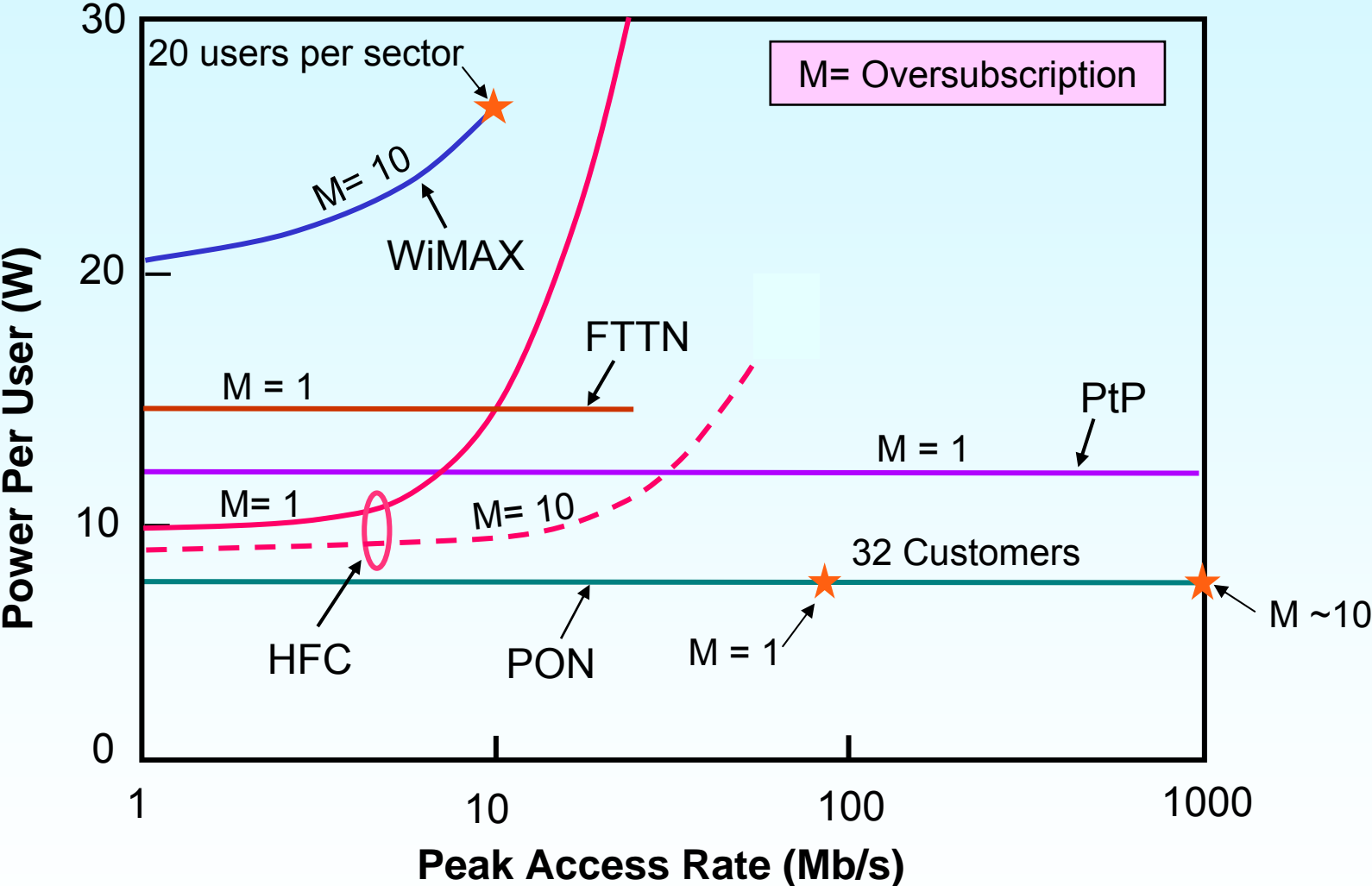

PON FTTH is "greenest"

Low-Power States in User Modems



EUROPEAN COMMISSION
DIRECTORATE -GENERAL JRC
JOINT RESEARCH CENTRE
Institute for the Environment and Sustainability
Renewable Energies Unit

Code of Conduct on Energy Consumption of Broadband Equipment

Draft Version 3

Issue 15 – 17 July 2008

“With implementation of this Code of Conduct,... 5.5 Millions tons of oil equivalent (TOE) will be saved per year.”

Extract:

	Off-State (W)	Low-Power State (W)	On-State (W)
ADSL-CPE	0.3	3.5	4.0
VDSL2-CPE	0.3	4.5	6.0
GPON ONU	0.3	5.0	9.0
PtP ONU	0.3	3.0	5.0



Network Energy Consumption per Bit

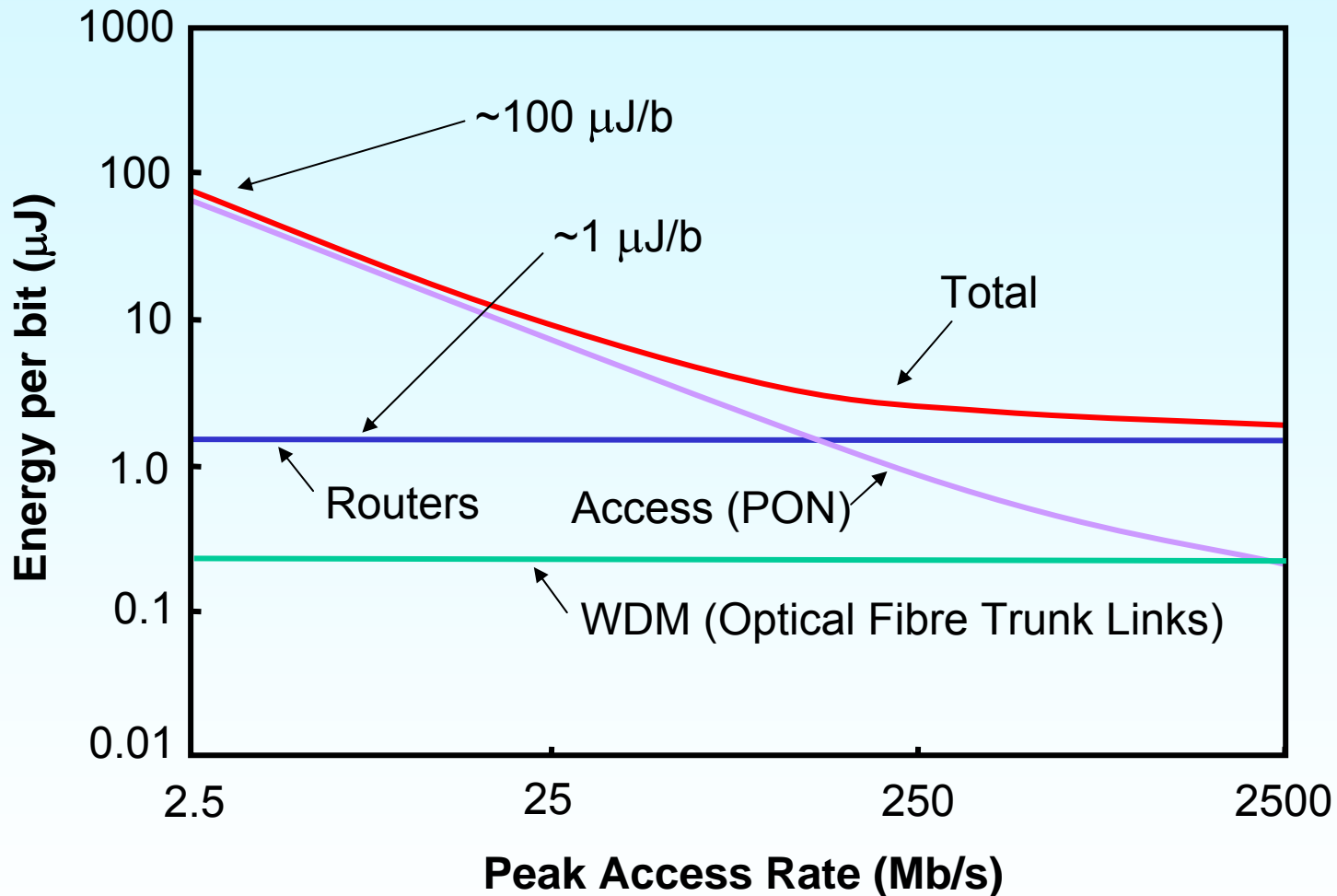

Energy per Bit in Network Devices

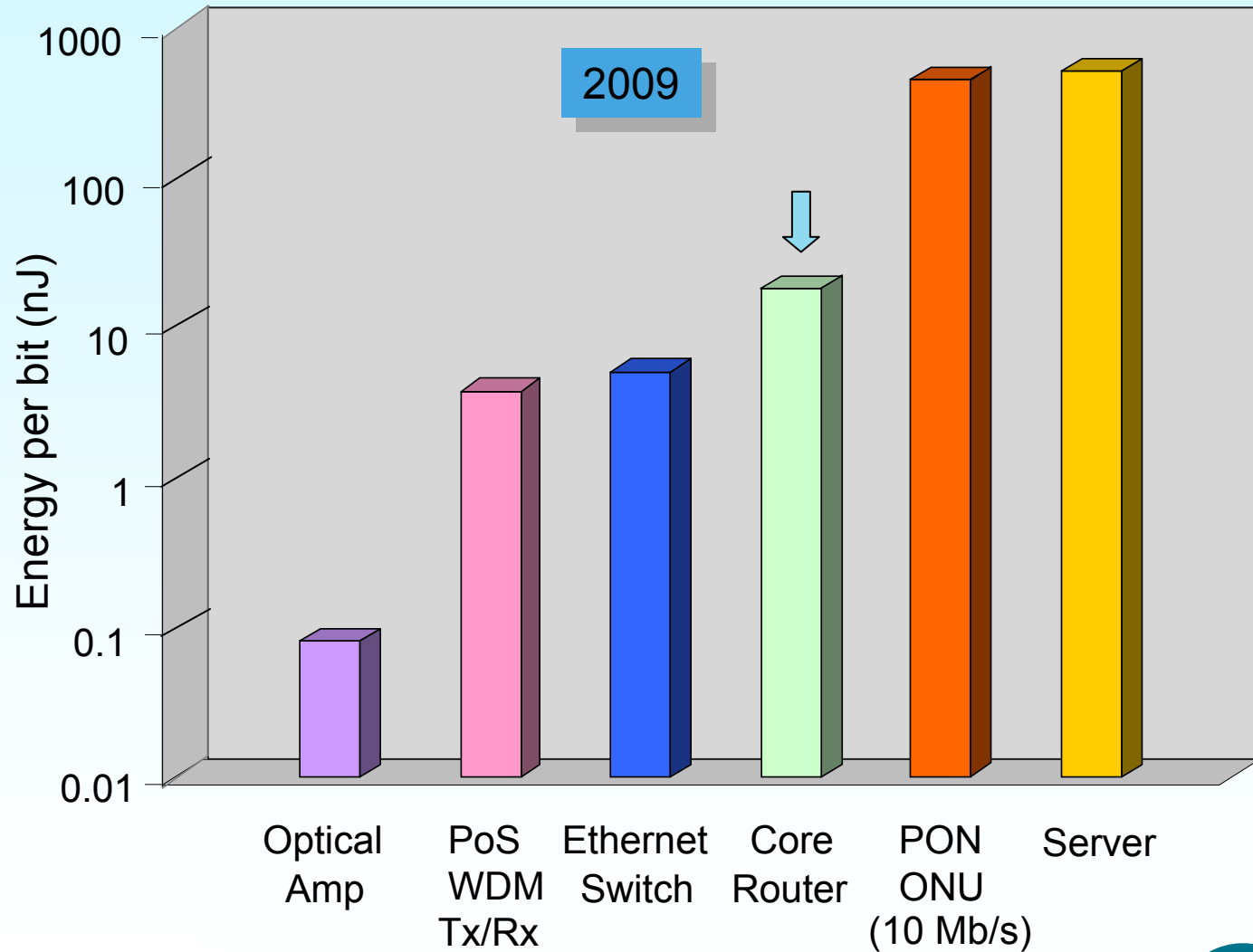

Cisco CRS-1 Router

Largest Routing System available today

Linecard Chassis: 1.28 Tb/s, 13.6 kW

Switch Fabric Chassis: 8 kW



Power consumption

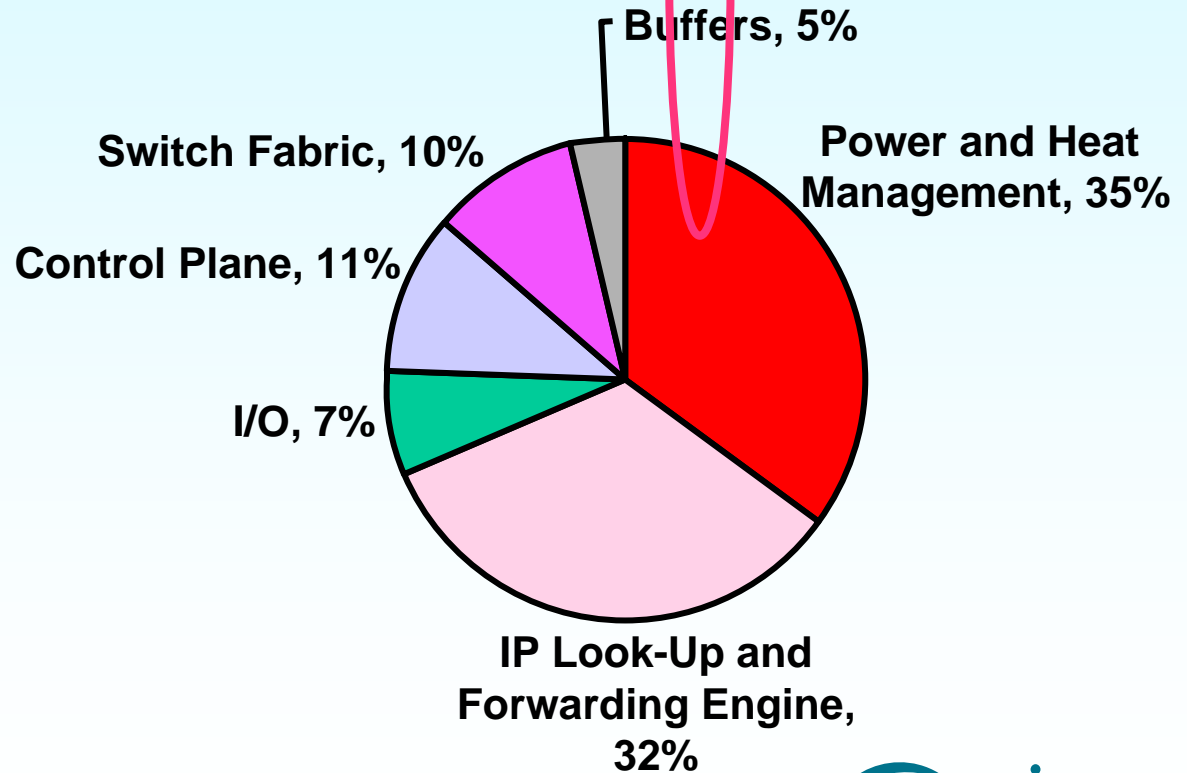

Energy in Electronic Integrated Circuits

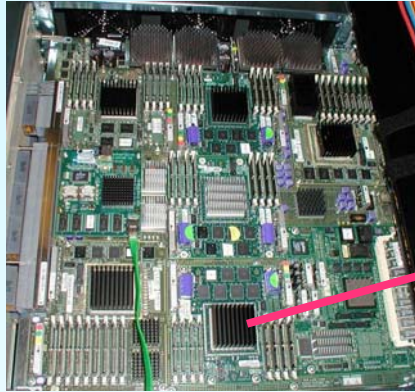

Linecard

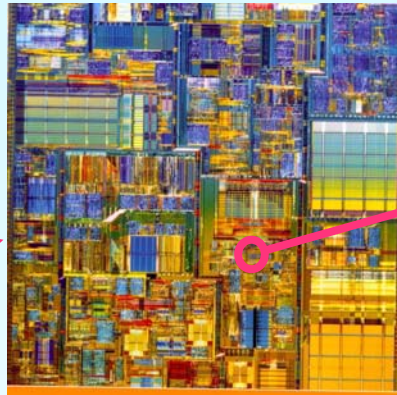

CMOS ASIC

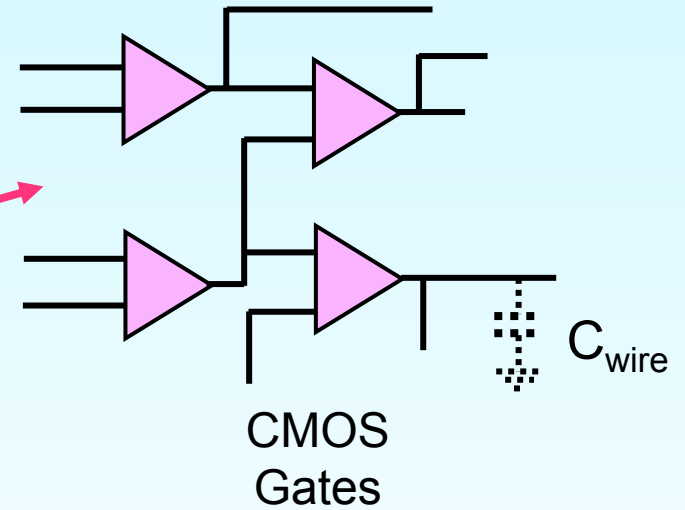

$$\text{Energy} = \sum E_{gate} + \frac{1}{2} \left[\sum C_{wire} \right] V^2$$

$$\text{Power} = \text{Energy} \times \text{Bit Rate}$$

Switching Energy in CMOS

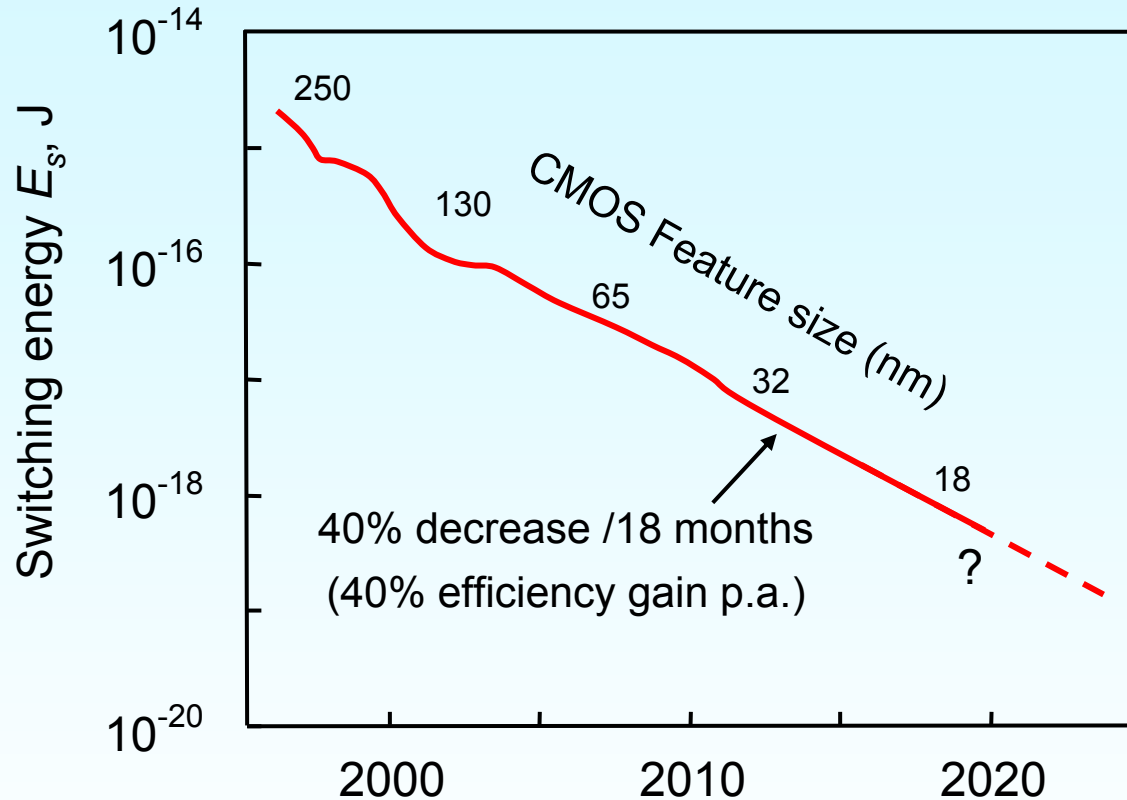

Moore's Law: Number of transistors x 2 each 18 months

Router Capacity Growth

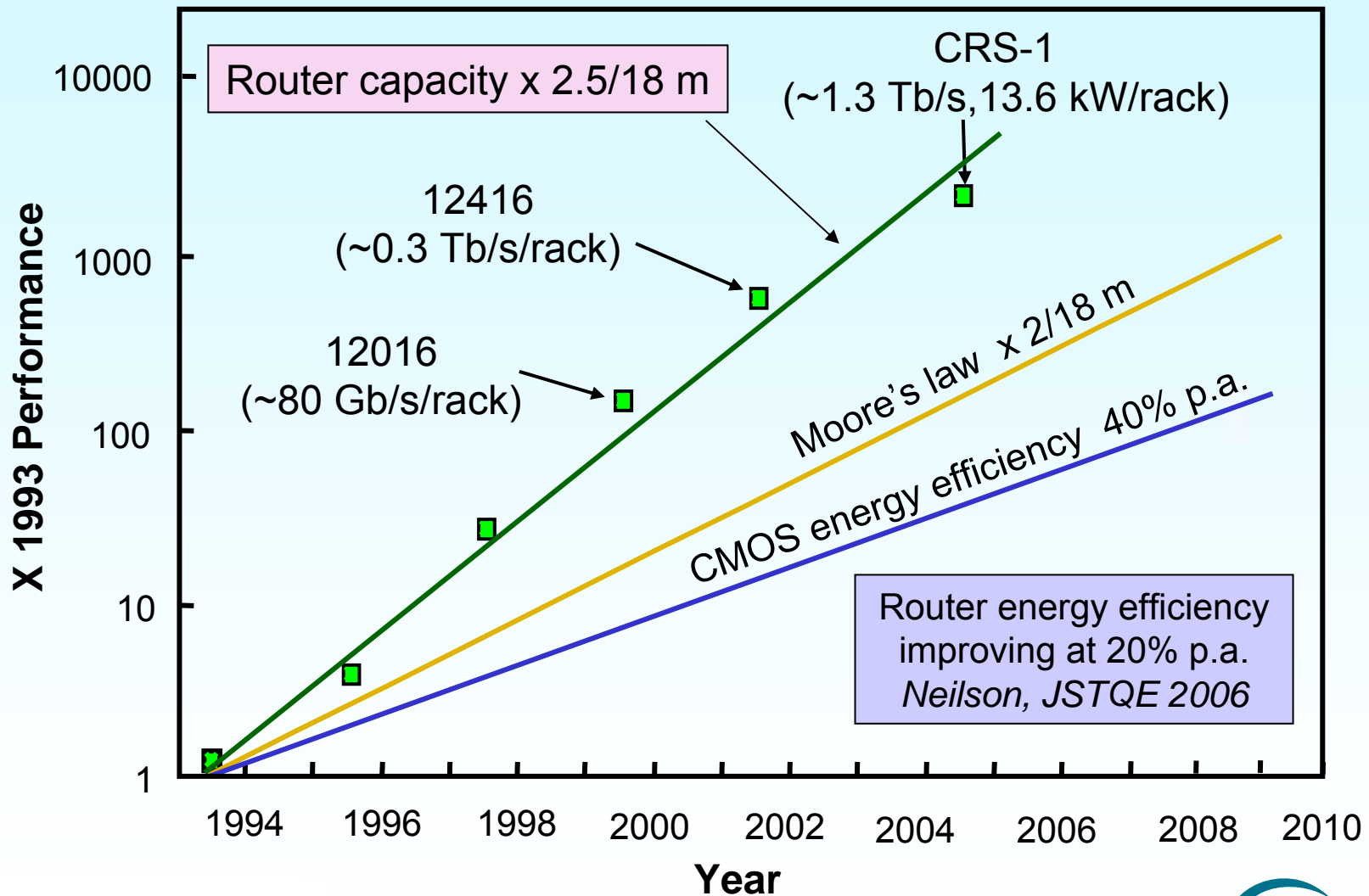

Based on G. Epps, CISCO, 2006



Effect of Efficiency Gains

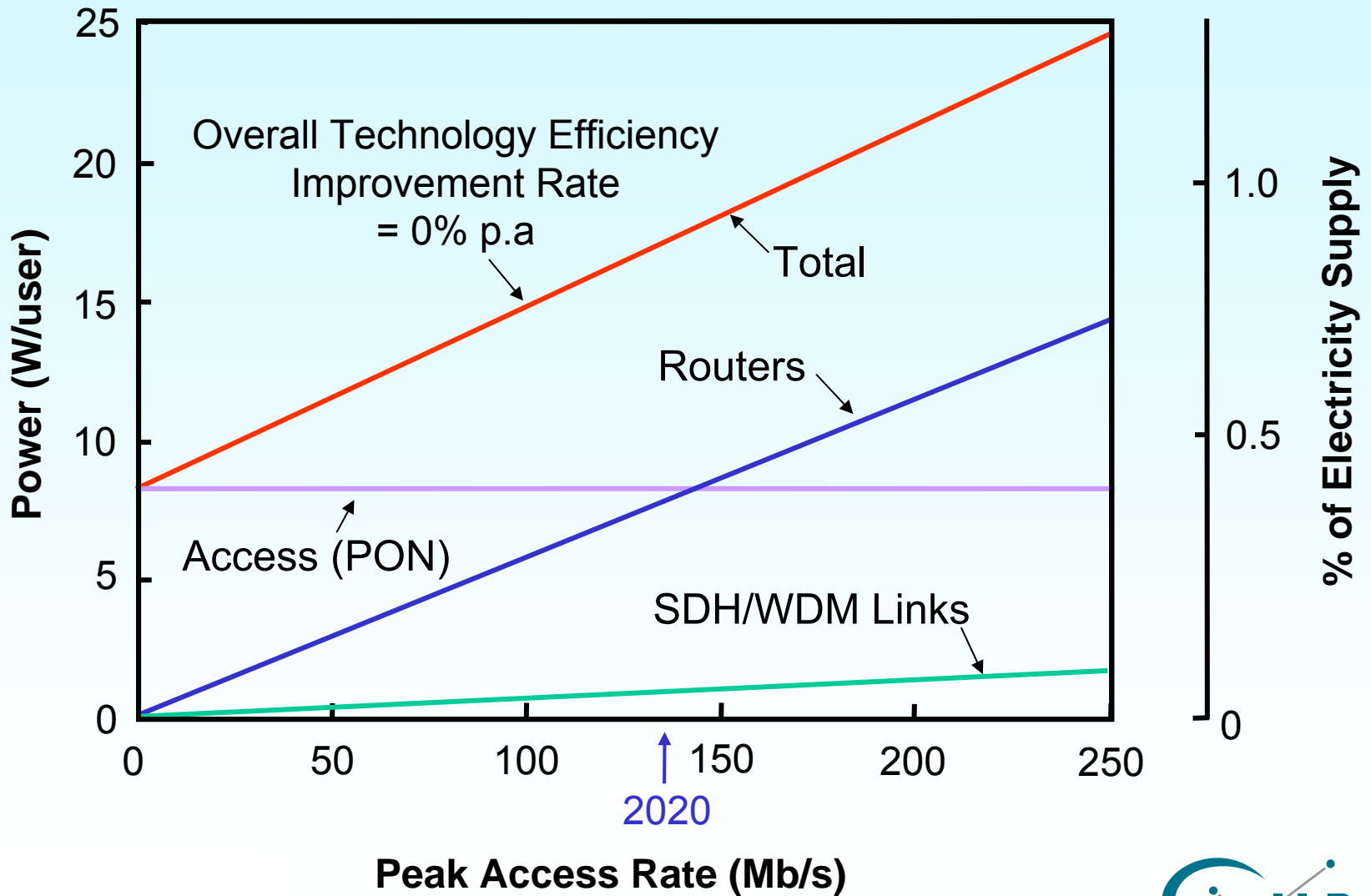

Effect of Efficiency Gains

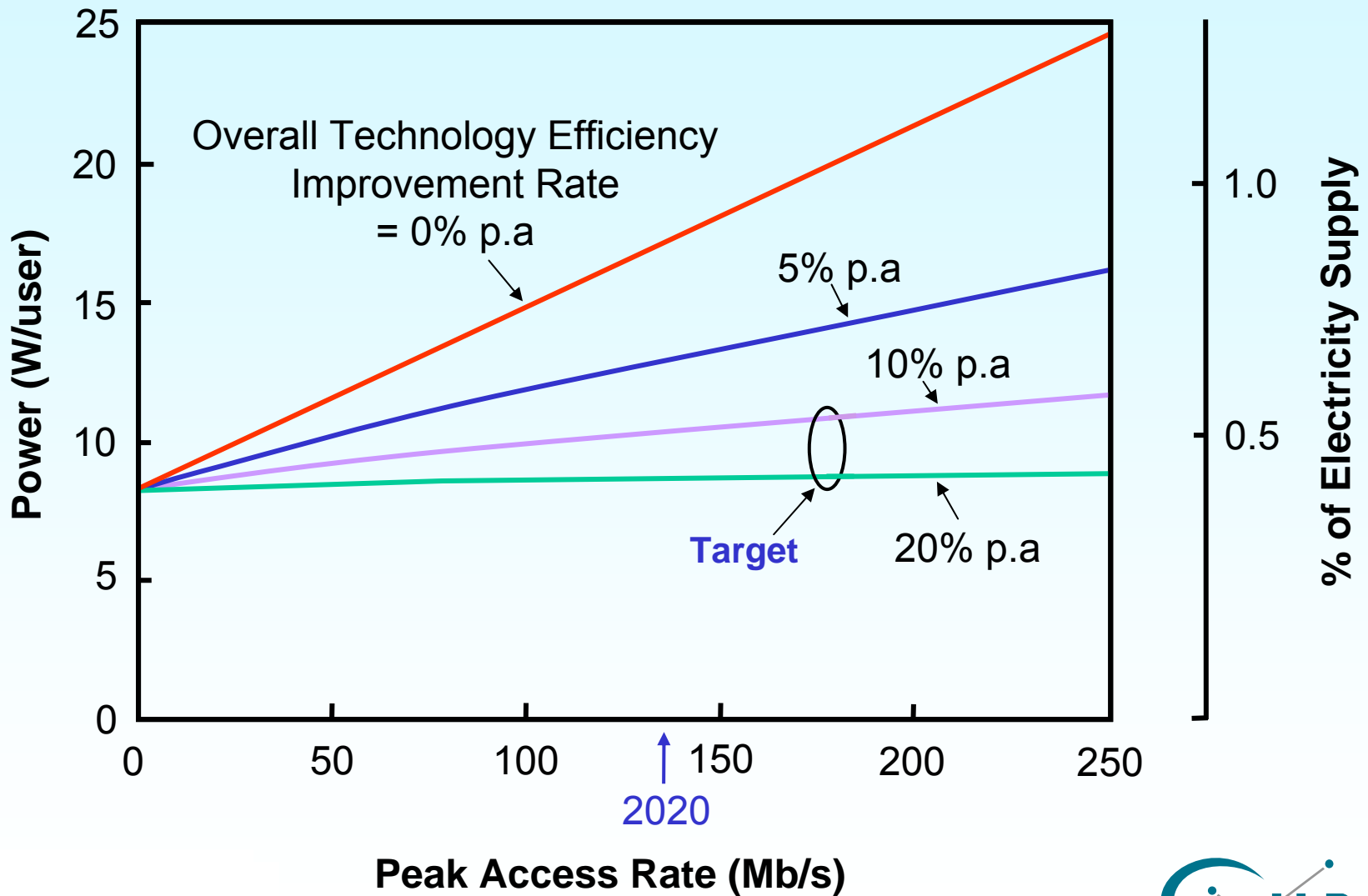

Towards Energy-Efficient Networks

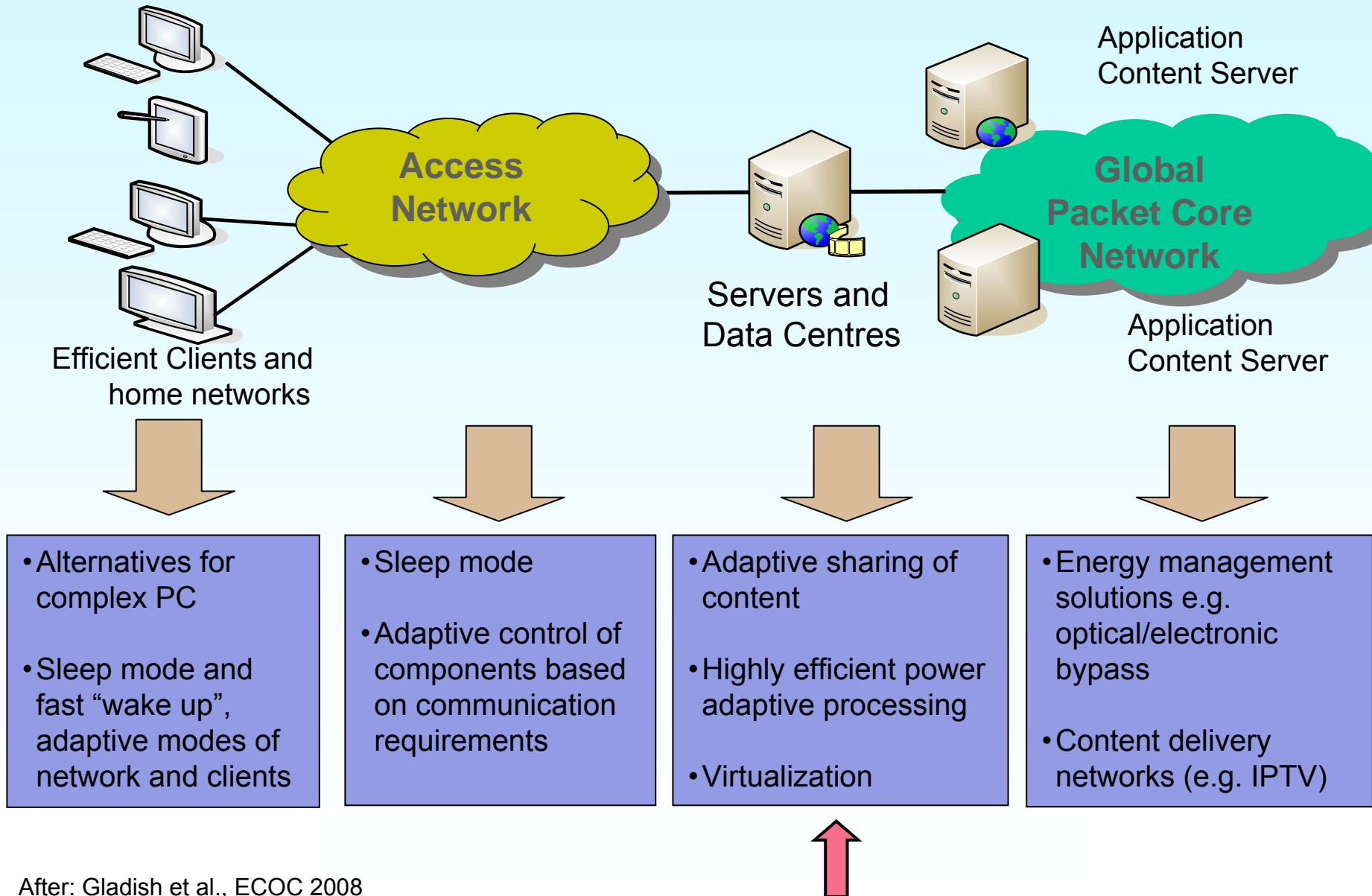

Data Centers

- Data center electricity consumption is ~1% of the global total¹
- Energy consumption of data centers worldwide doubled between 2000 and 2006 ²
- Incremental US demand for data centre energy between 2008 and 2010 is the equivalent of 10 new power plants²



1 MW Data Center

¹Koomey, 2008

²Revolutionizing Data Centre Efficiency—Key Analyses”
McKinsey & Company, April 2008.



Energy Consumption in a Data Centre

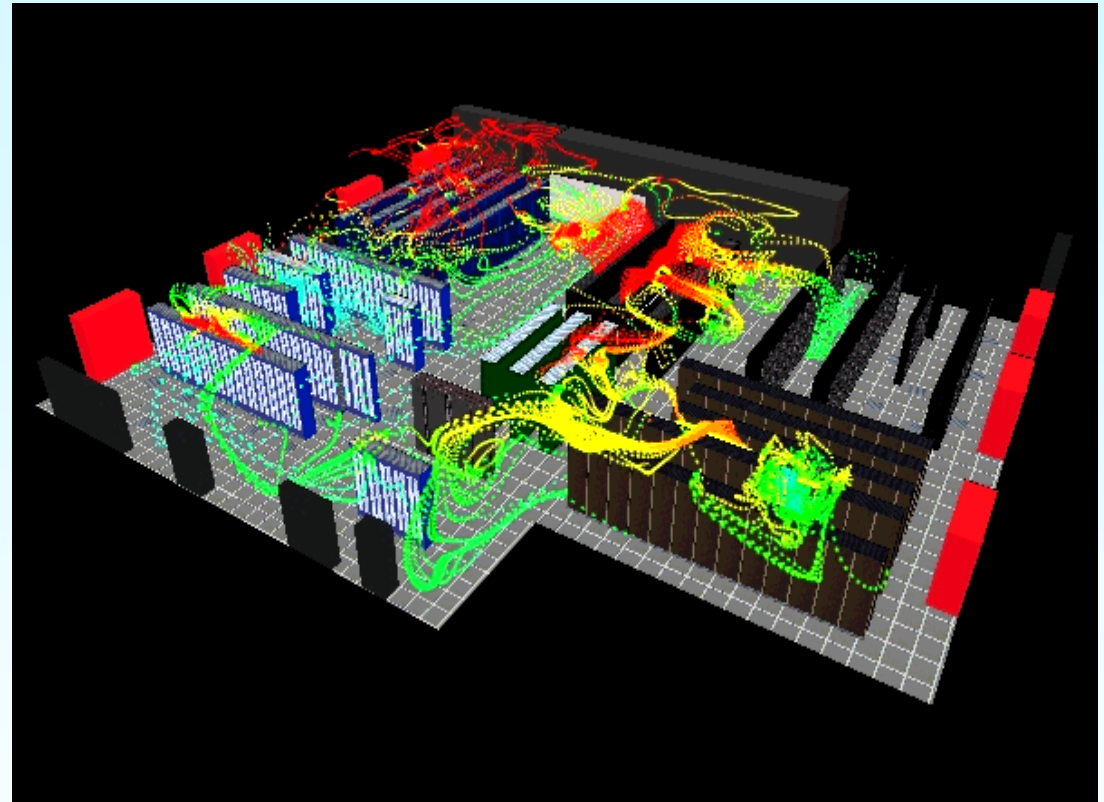
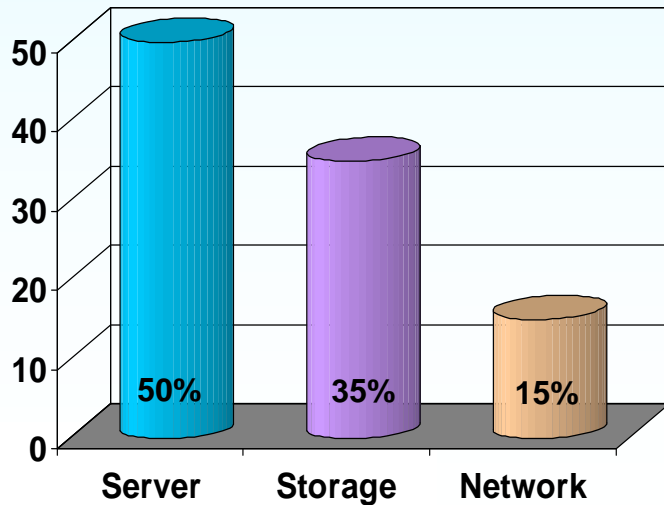
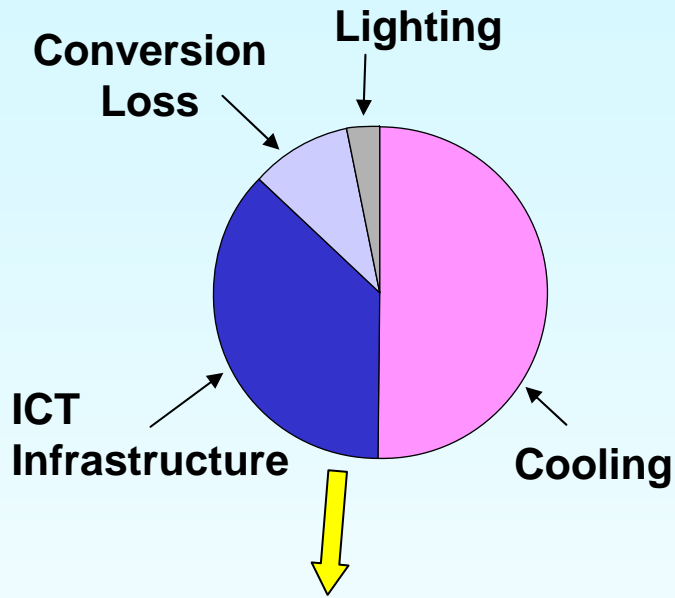

“Burden factor” of 1.8 to 2.5 for power consumption associated with cooling, conversion/distribution and lighting

Sources: EYP Mission Critical Facilities, Cisco IT, Network World, Customer Interviews, APC



Information Logistics

Management of data, including, transport, storage, and processing

Some typical issues/questions:

- Wired vs. wireless broadband access
- Can Cloud Computing save energy?
- Renewable energy sources
- Physical vs. Internet delivery of data
- Can Internet Travel replacement save the planet?
- Optimum design of Video on Demand systems

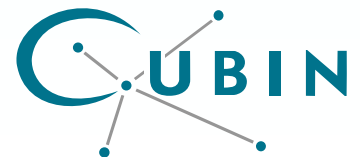

Cloud Computing

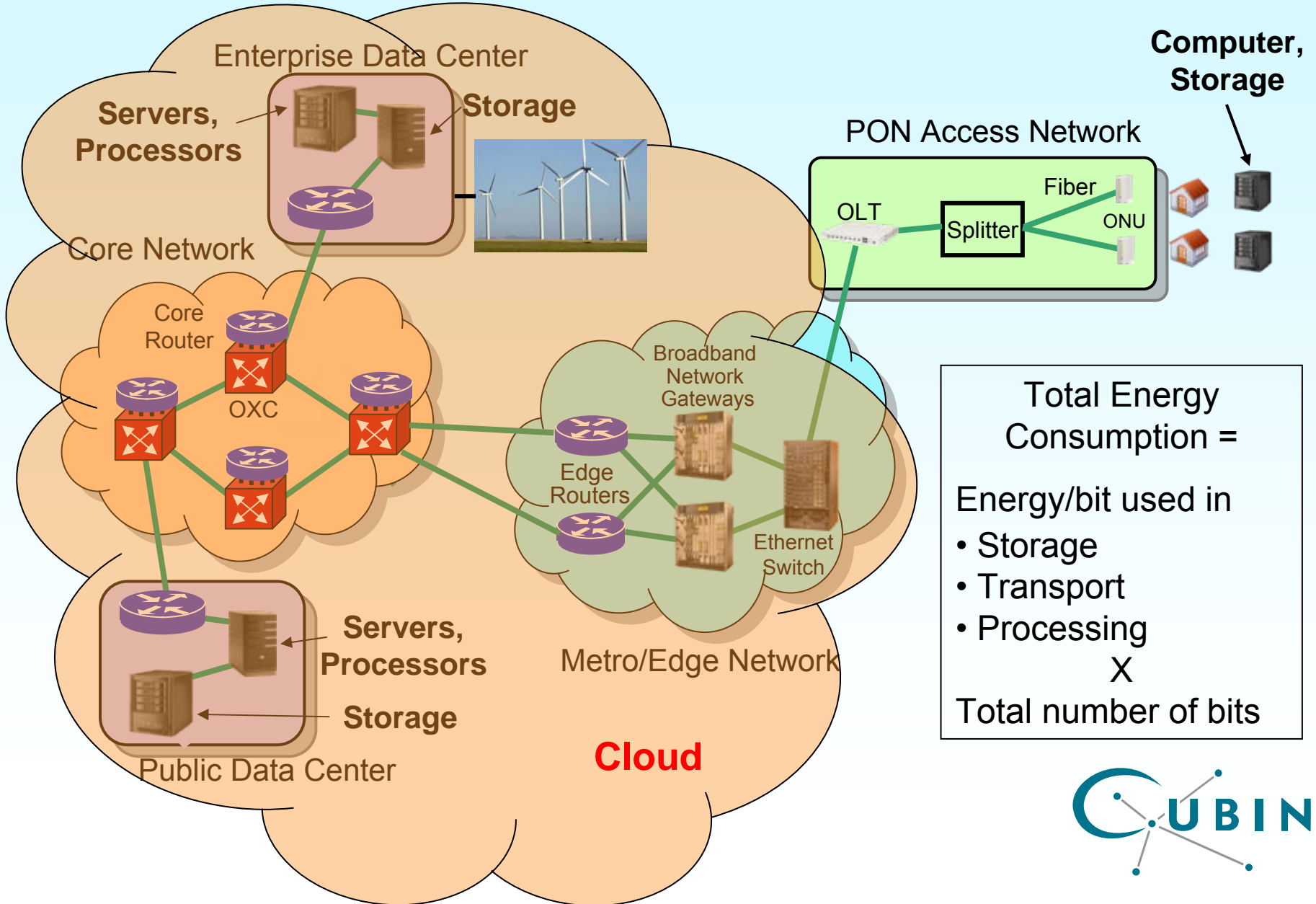

Three Cloud Computing Scenarios

- **Software-as-a-Service**
 - Stored on user's computer with updates downloaded regularly
- **Service Bureau**
 - Most tasks done on lower end user machine, outsource the "big" jobs
- **Computing-as-a-Service**
 - Hosted and run on provider computer "farm" with data initially uploaded from user (Thin client model)

Can cloud computing save energy ?



Service Bureau

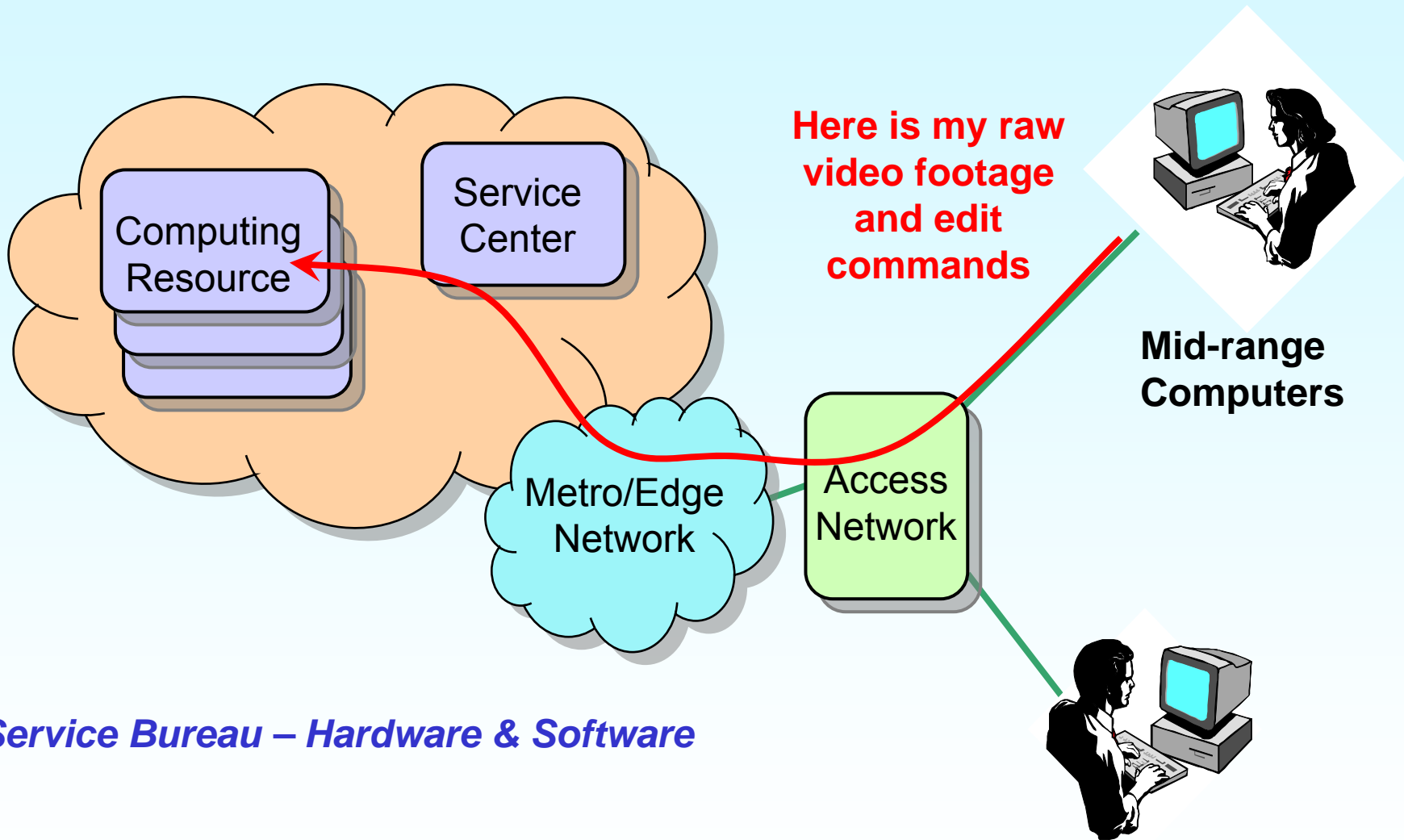

Service Bureau – Hardware & Software

Service Bureau

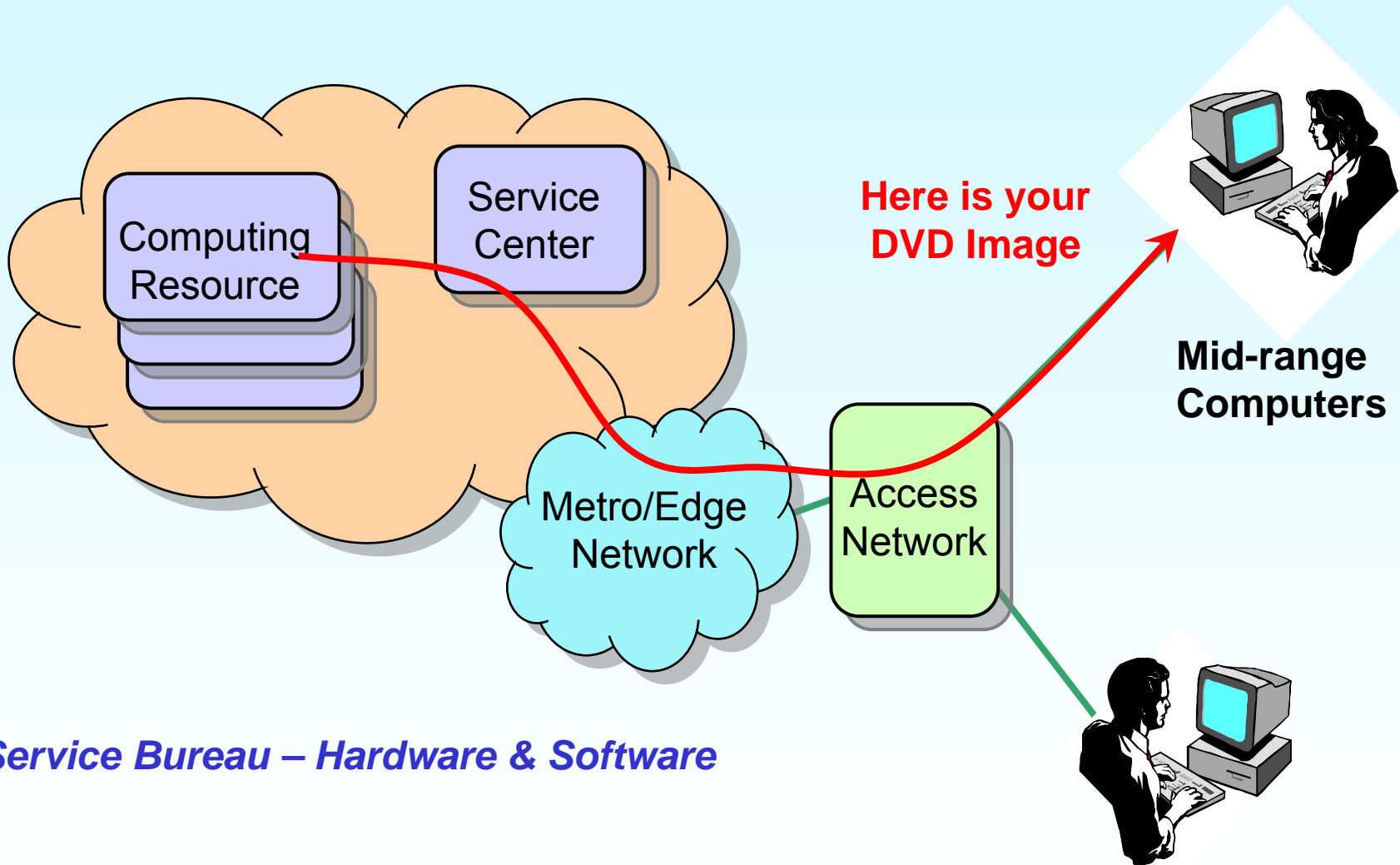

Service Bureau – Hardware & Software

Energy Consumption of Service Bureau Model

Computer used for 20 hrs/week, plus some video encoding of ½ hour videos

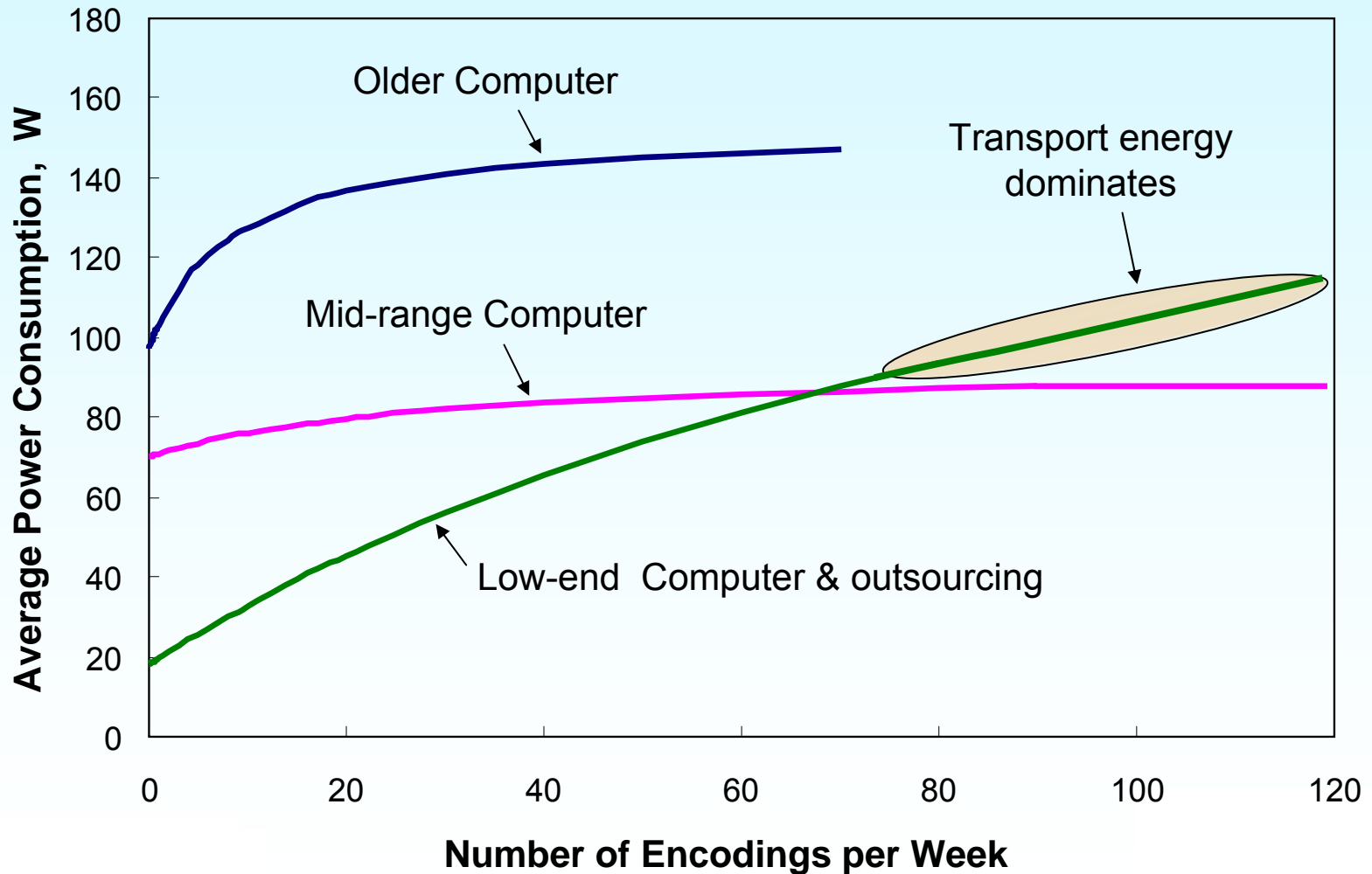

Following the Sun and the Wind

Making best use of renewable energy

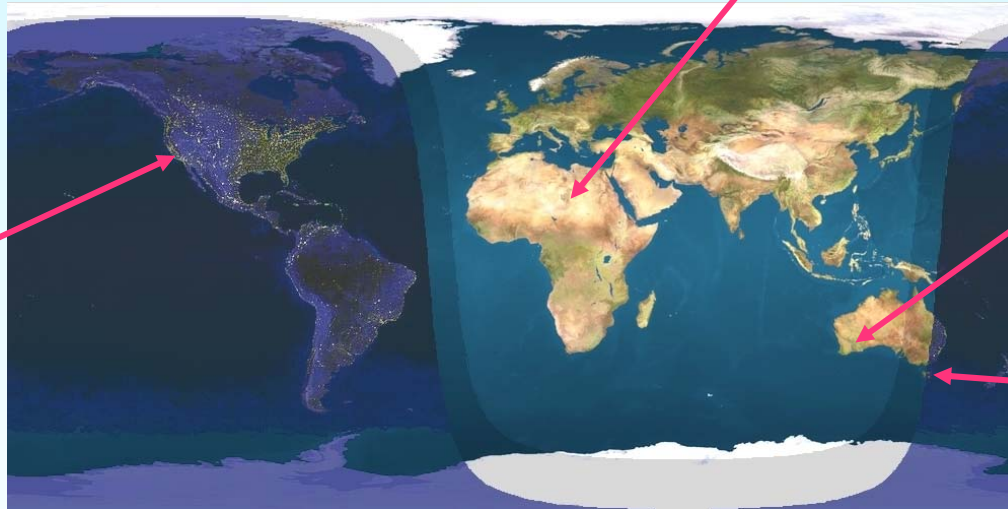

- Locate computing and storage resources near sources of renewable energy
- Move data to follow the sun and winds
- Requires many orders of magnitude increase in a data transport capacity
- Transport/efficiency trade-off



Data by Airmail vs. Data by the Internet

Data by Airmail:

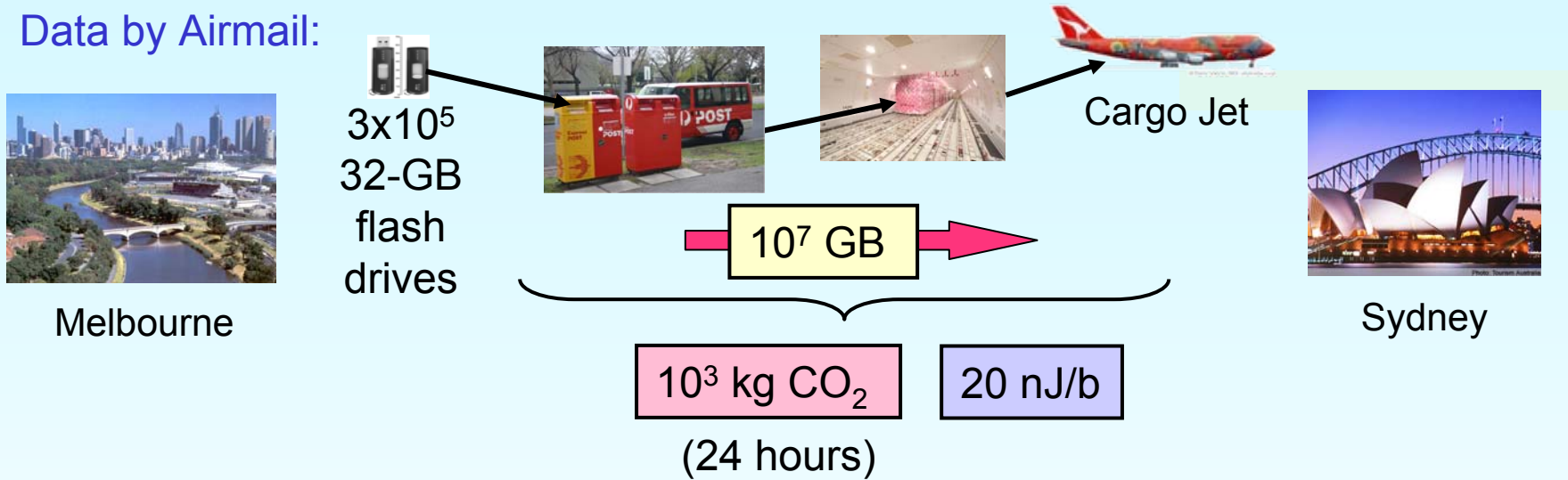

Data by Internet:

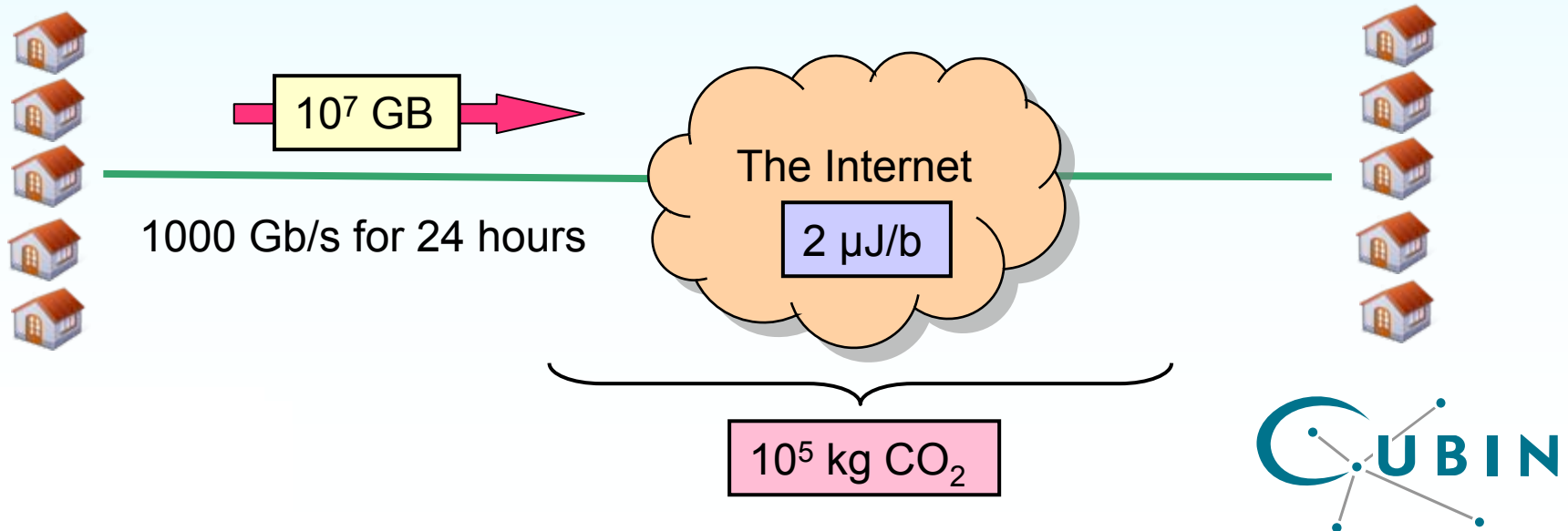

Energy Consumption per Bit

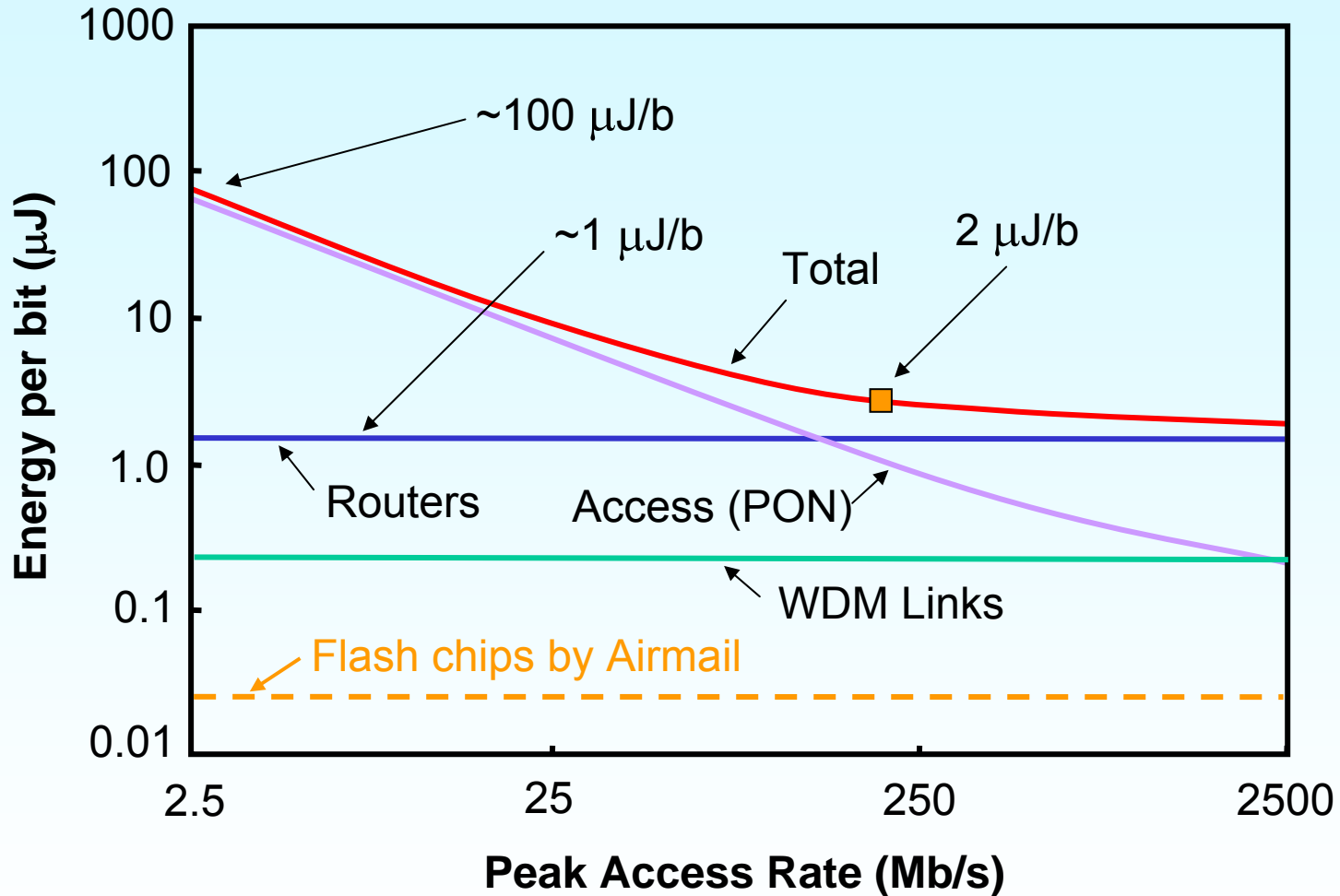

Using the Internet for Travel Replacement

Video Conferencing



Travel Replacement - Greenhouse Impact (CO₂)

Air Travel



Melbourne



~500 kg/person return

Business Meeting



Sydney

Video Conferencing



2 X 1 Gb/s for 6 hours
= 4 TB

~5 kg/person



Rod's Telecommute Calculator

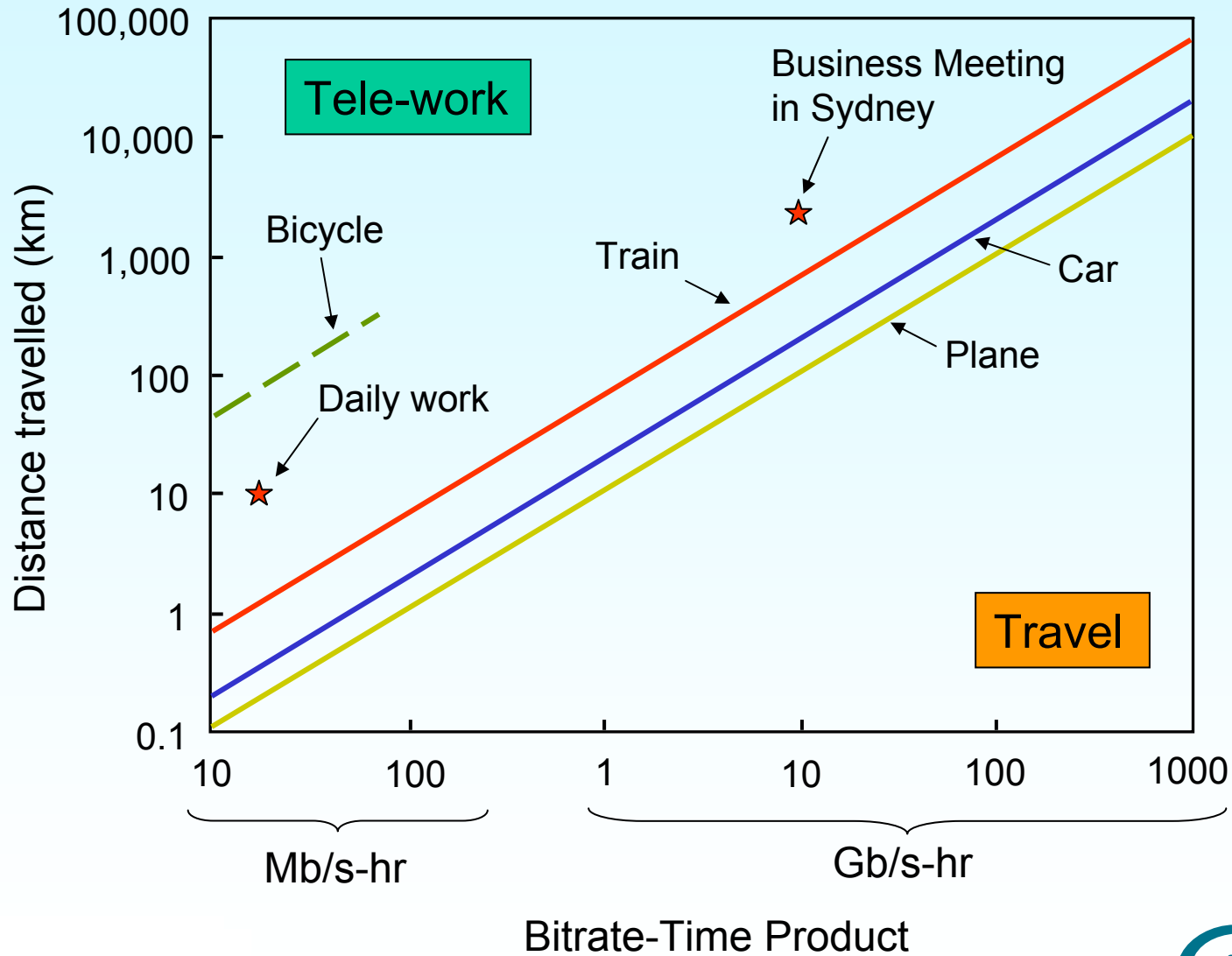

The Khazzoom-Brookes Postulate

- Energy efficiency at micro level → reduction of energy use at this level
- *But* leads to an increase in energy use, at the macro level
- Example:
Wide bodied passenger aircraft → lower costs per passenger → large increase in air travel → increased greenhouse emissions

“Energy efficiency is absolutely the wrong approach to network design.

The objective should be to make the network carbon neutral”

- Bill St. Arnaud, CANARIE

D. Khazzoom *Energy Journal*, 10, 1987, L. Brookes *Energy Policy*, 20, 1992

Inhaber, “Why *Energy Conservation Fails*”, Quorum, 2002

H. Herring, <http://technology.open.ac.uk/eeru/staff/horace/kbpotl.htm>



Some Interest Groups and Organizations



NIPP
Network Interface, Power, and Protection Committee

<http://www.atis.org/0050/>



GeSI
GLOBAL e-SUSTAINABILITY
INITIATIVE

<http://www.gesi.org/>



**ITU and
Climate
Change**

<http://www.itu.int/climate>



the green grid™
get connected to efficient IT

<http://www.thegreengrid.org/home>

wattwatt
generated by bright sparks

<http://wattwatt.com/>

[ICTandclimatechange.com](http://ictandclimatechange.com)

<http://ictandclimatechange.com/>



Summary – The Way Forward

- Energy consumption of the Internet is small, but growing
- Internet energy consumption dominated by
 - Access network today
 - Core network in the future
- A multi-faceted approach needed to build a green Internet:
 - Improved efficiency in electronic and photonic devices
 - Low-energy switching techniques
 - Improved architectures
 - New protocols
- Information Logistics
 - A new approach to network design and management

Melbourne Information Logistics Centre (MILC)?

Centre for Information LOfistics (CILO)?

